



Whitepaper

Transportation



# An engineer's guide to the DC power train architecture of an electric vehicle

Dermot Byrne, Director Industry Marketing, Transportation, TTI Europe

# Executive summary

The adoption of electric vehicles is steadily growing across Europe, and is not just limited to automobiles but includes light commercial vehicles such as vans, heavy haulage trucks, and public transport buses. There are a number of different approaches to electric vehicles too, with hybrid (HEV), plug-in hybrid (PHEV) and fully-electric vehicle (EV) versions.

In this Whitepaper, we first take a brief look at the electric vehicle landscape and the architectural design of an EV and PHEV. A broad overview of the key sub-systems/main building blocks of an EV/PHEV is then given – comparing electric cars, trucks, vans and buses.

The paper then discusses EV power distribution, explaining the challenges involved in routing high currents around the vehicle and the need for reliable and robust interconnects. Examples of EV power distribution interconnect products are included. Other distribution components such as relays, contactors and fuses are discussed with technical details of some products explored.

Finally, a section on motor drive inverters and auxiliary DC-DC power conversion describes the architectures and components used, including capacitors, inductors, choke modules, transformers and circuit protection elements.

With their environmental benefits, electric vehicles (EVs) are the future of transportation with companies such as Volkswagen, for example, planning to produce around 50 different battery-electric models across its 12 auto brands by 2025. Cars make the headlines with the biggest volume and high-end features such as autonomous driving and extreme performance modes but vans and buses are in the mix as well with electric trucks to follow. Growth rates predicted are impressive with 37.1% Compounded Annual Growth rate (CAGR) estimated for cars for example, **Figure 1**. (Source: European Automotive Manufacturers' Association - ACEA and European Alternative Fuels Observatory - EAFO)<sup>[1][2]</sup>.

**Figure 1: Total vehicle sales in the EU in 2017. AFC – Alternative Fuel Car**

ACEA / EAFO - Market Data 2017								
Vehicle Type	EU production Quantities	EU Growth %	# of EU Plants	% Diesel	Vehicle Lifetime	% AFC	EV / HEV Production	EV Growth
Cars	16,500,000	3.4%	140	50	10	5.5%	902,546	37.1%
Vans < 3.5T	2,200,000	3.9%	39	96	10.7	1.5%	15,855	23.1%
Trucks > 3.5T	417,339	0.0%	59	98	11.7	1.0%	Not Available	
Buses	40,380	-0.5%	50	90	9.4	8.5%	715 - E-Bus 2736 - E-Trolley	Top 10 only

There will be around 80 models of electric cars of all types on the road by 2020. For vans or light commercial vehicles, the mix and volume are smaller, but still with a predicted 23.1% CAGR. In 2017, for van sales, French companies dominated the top 5 Battery Electric Vehicle (BEV) figures and German companies dominated in Plug in Hybrid Electric Vehicles (PHEV), **Figure 2**, with far eastern manufacturers sure to make inroads in the future.

**Figure 2: Manufacturers of electric vans 2017**

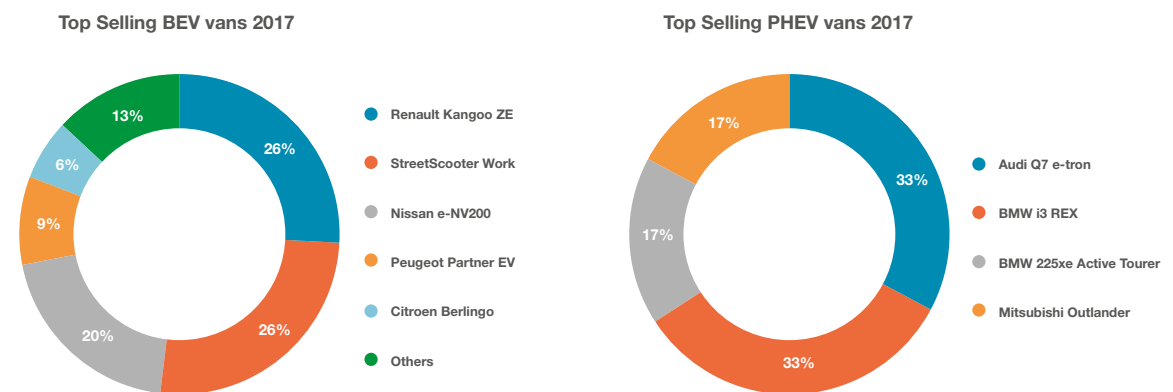

There are relatively few battery and hybrid buses on the road if you exclude trolley versions. Market CAGR is only 8% but as the fleet ages, electric buses are expected to increasingly replace diesel types with up to 20% share in 2022. (Source: Frost and Sullivan).

Electric and hybrid-electric trucks are a relative rarity today but are predicted to form around 20% of the fleets in the US, Europe and China for light and medium duty vehicles by 2030 with heavy duty trucks lagging further behind. (Source: McKinsey Center for Future Mobility).



# Electric Vehicle architecture

Common architectures for electric vehicles are all Electric (EV), Hybrid Electric (HEV) and Plug-in Hybrid electric (PHEV). The main building blocks of an EV/PHEV in a car are shown in **Figure 3**. It is common also to have a high voltage DC input for fast charging from roadside stations. Buses and trucks have similar arrangements but with additional features such as high voltage air compressors for braking and brake resistors which slow the electric motors when needed rather than relying on frictional components. **Figure 4** is an example of the arrangement in a Mercedes-Benz truck.

Figure 3. EV/PHEV architecture building blocks (source Littelfuse)

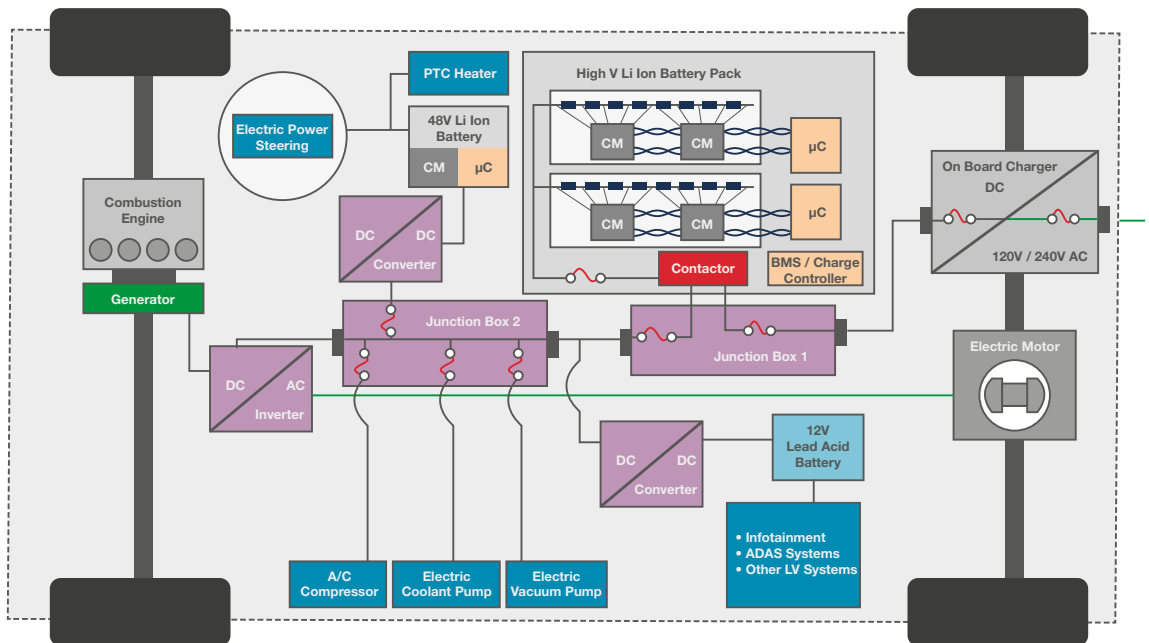
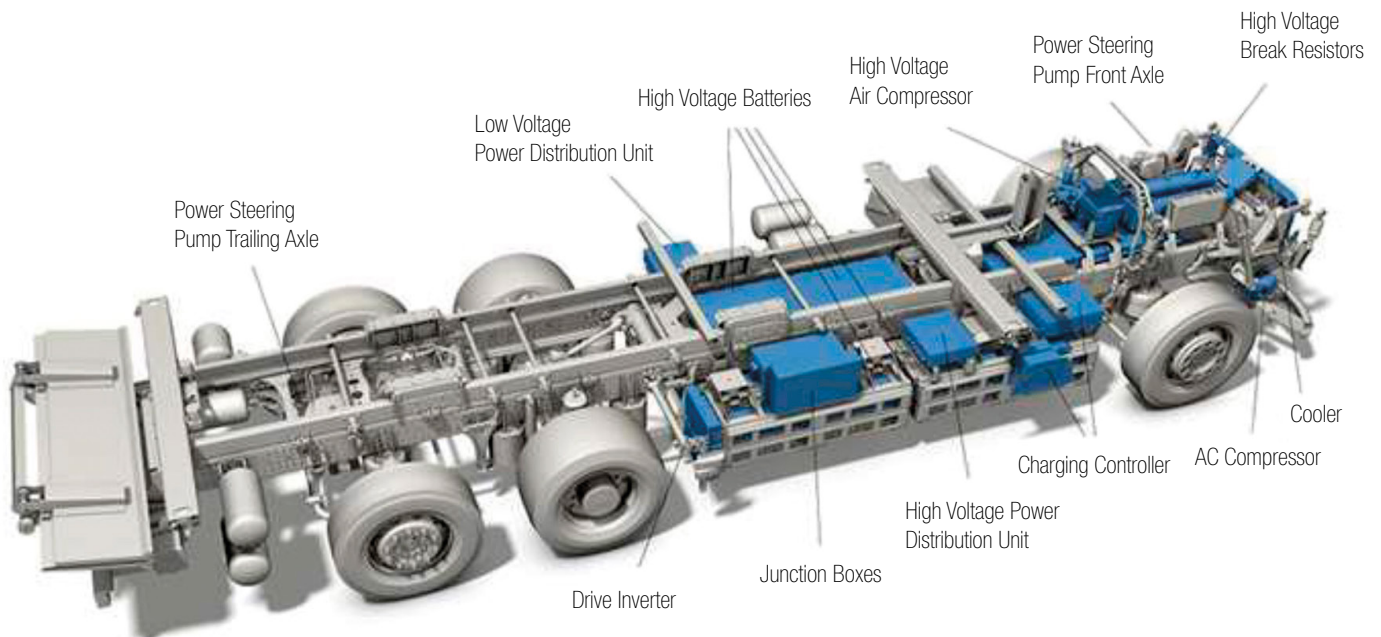

Figure 4: Typical Mercedes-Benz electric truck powertrain



# Distributing power in electric vehicles

The blocks in Figure 3 show that power is distributed in an electric vehicle at multiple levels. The main traction battery is typically rated at 300 – 400V comprising series and parallel combinations of small cells to give the overall power rating required. The Tesla 85kWh battery pack for example has 7,104 18650-size lithium-ion cells in total. Other voltage rails generated can be 48V for functions such as power steering and 12V for legacy equipment such as infotainment and lighting. High voltage AC is present up to 240VAC nominal for single phase on-board chargers and sometimes higher levels still for three-phase charging systems. Around 400V is also sometimes input to the vehicle from fast charging roadside stations. The currents involved on the various rails range from tens of amps on the 12V circuits to peak levels of around 1000A from the batteries in high performance cars such as the Tesla model S with its 100kWh battery fitted, with a peak power rating of 451kW.

Distribution of power is a complex issue to avoid losses while maintaining reliability of connections in the sometimes-harsh automotive environment. Voltage levels are generally classified as 'hazardous' so insulation systems need to be considered and EMC (Electro-Magnetic Compatibility) is an issue with sensitive signalling often in close proximity to high power switched currents such as those driving the three-phase traction motors. Shielded cabling is therefore often required. All this, with the need for modularity, requires designers to select connectors with some care.

Shielded connectors from the Amphenol 'Powerlok' range can be considered with current ratings up to around 650A and 1000V insulation rating. They are over-moulded metal construction, IP67 rated and are available with up to three pin positions in straight and right-angle configurations. Other connectors in their range such as the 'HVSL' and 'EPOWER LITE' suit lower currents and more protected environments where a cost-saving plastic construction is acceptable.

Specifically for high voltages, the Aptiv (formerly Delphi) AK series of cost-effective connectors features high shielding performance and innovative cable strain relief for superior vibration immunity. With a temperature range of -40°C to +140°C, the series includes panel-mount, pass-through connectors rated up to 200A in one, two or three ways and the HV890 AK Class 4 types, a two-way 170A-rated connection system with 'HVIL' or High Voltage Interlock. HVIL is a separate closed circuit built into the connector which mates-last, breaks-first which can signal to the main voltage source that mating/demating is in progress and high voltage should not be applied, avoiding arcing and access to dangerous voltages. The Shield-Pack™ HV280 types also have HVIL and include a class 1 female connector with two or three power circuits, rated at 32A.

Like the Amphenol and Aptiv range of EV shielded connectors, the Molex 1000VDC/250A-rated 'Imperium' range also features 'HVIL' or High Voltage InterLock. TE Connectivity has similar offerings.

# Isolating power in electric vehicles

Figure 3 also shows that comprehensive protection for the power electronics is needed in the form of isolating contactors and fuses. Under fault conditions, these components may need to break peak currents of thousands of amps while isolating hundreds of volts safely. Contactors rated for these conditions are often specified to be driven, not by a continuous coil voltage, but with a Pulse Width Modulated (PWM) signal which varies from 100% on actuation to some lower value after perhaps 500ms, with a repetition rate of around 2kHz. This is done to reduce heat dissipation in the coil and takes advantage of the fact that contactors and relays have an 'actuating' current and a much lower 'holding' current. In the automotive environment, the minimum holding current is exceeded by some margin to allow for the possibility of shock and vibration breaking the contact spuriously.

Smaller relays have applications in the power circuits as well, sometimes in parallel with main contactors with a series resistor to allow 'pre-charge' of loads such as inverters with their high inrush current. The pre-charge relay closes first with the series resistor limiting current to some low value, perhaps 20A. After the load inrush is over and the applied voltage has risen to typically 90% of the final value, the main contactor is actuated with little further inrush current, shorting the pre-charge relay and resistor.

Suitable relays and contactors can be found in the TE Connectivity range with main contactor parts rated up to 6,000 amps peak current in their EVC 250 range and others at 1000VDC for high battery voltage applications such as their K1K range (Figure 5). Relays in the PEW (Panasonic) automotive range are available with up to 600A peak operating current and 2,500A breaking current with the parts featuring inert gas filling to suppress arcs. Some types have a separate 'holding' coil for reduced power dissipation without resorting to PWM techniques. Another major player is TDK with up-coming automotive contactor products rated for 750A peak current and 900VDC. With coil power ratings of 6W but an operating to hold current ratio of around 4, these contactors benefit from PWM coil drive to reduce heat dissipation.



**Figure 5: Typical automotive grade contactors/relays (TE Connectivity)**

When fuses are specified for disconnection of circuits under gross failure conditions, these are often seen as bolt-down types, particularly at high current ratings, and can be up to perhaps 30mm diameter for the largest types. Extreme care should be taken in the sizing of powertrain fuses so that they do not open under any transient, but normal operating condition. A fuse causing motor disconnect, for example, is seen as a critical-to-life event and therefore, such is the importance of this application, you will see manufacturers giving fuses serial numbers and lot date codes for supply chain traceability as necessary. Heat dissipation from expected current transients through fuses should also be considered with manufacturers' recommendations for the fuse/conductor interface followed carefully. Automotive-grade EV power line fuses are available from manufacturers such as Eaton and Littelfuse.

## Motor drive inverters

Key to the road performance of an electric vehicle is the power conversion process from battery to motor drive. Motors commonly used are the Permanent Magnet (PM) type which has high efficiency and high torque but sometimes induction types are seen, such as used by Tesla, which are simpler and robust but are less efficient. Both types are driven by three-phase AC at typically a few kHz which has to be derived from the main traction battery DC rail. The typical drive architecture is shown in **Figure 6**: a boost converter to a constant higher 'DC-link' voltage followed by a bridge with 6 active switches, although in practice each may be many in parallel to achieve the overall power rating, (14 in the case of the Tesla model S). The switches are normally IGBTs which limit operating frequency, but MOSFETs, particularly Silicon Carbide (SiC) types, running at more than 100kHz are proposed for the future, reducing size while increasing efficiency. The PWM drive to the boost converter and bridge can be configured such that power flow is in reverse, providing regenerative energy to charge the battery when the vehicle is coasting, with the traction motors acting as generators.

**Figure 6: EV inverter architecture**

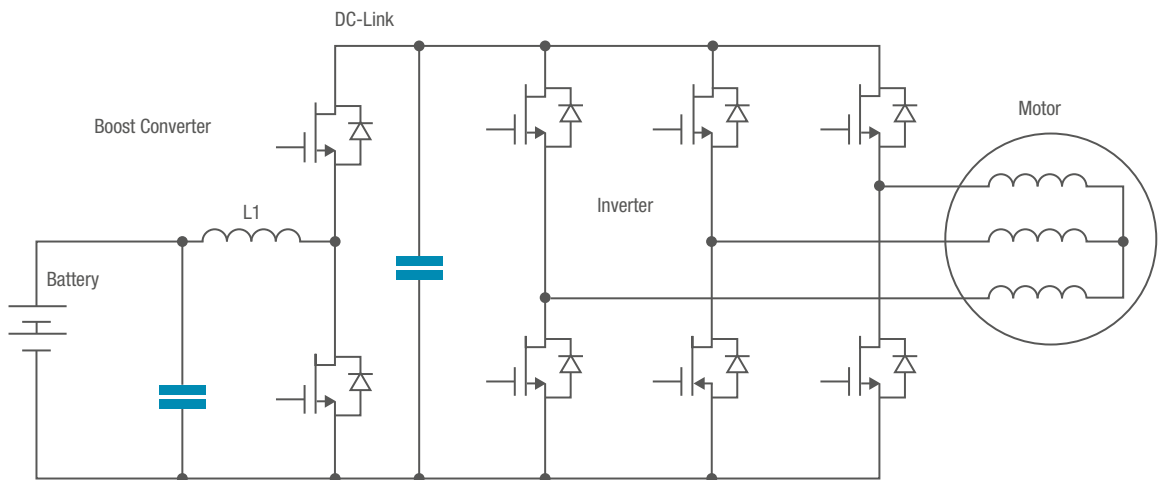

While semiconductor switches do the heavy lifting, inverters also need supporting components such as connectors, capacitors, inductors and protection circuits. Connectors have been discussed earlier but capacitors and inductors for filtering are key components as well. The DC link in Figure 6 needs high performance capacitors on it to provide a low impedance to AC, sourcing and sinking the large switching currents from the three-phase bridge. Metallised polypropylene types are the preferred solution with a good combination of high capacitance and ripple current rating in a compact size, with the added advantage of self-healing after over-voltage stress. Typical parts would be the Vishay 1848S/1849 series or Kemet C4A, C4DE and C44U series or FHC1 range from AVX. Electrolytic types sometimes seen in non-EV DC link applications are typically not used due to their temperature sensitivity and finite lifetime, although they do have a better capacitance/volume ratio than film types and can be considered for positions where there is less ripple current and temperature stress.

In **Figure 6**, the boost stage may in practice be several stages in parallel with interleaved switching phases to spread the stress over several inductors and reduce input and output ripple current. The inductors between them are required to store the total energy needed by the bridge circuit in the first part of the converter switching cycle and then release that energy at the higher boost voltage in the remaining part of the cycle. The inductors therefore are significant in size and will often be custom designs from companies such as Pulse Electronics.

Inductances, whether in filter networks or inherent in motor windings, produce voltage transients with changing currents. These can be damaging to the control and power circuits so EV powertrains will widely feature transient suppressors and EMI filters such as those from Vishay. Other protection components will include thermistors for inrush protection and temperature sensing again with a wide range available from companies such as Vishay and Littelfuse.

# DC-DC converters in EVs<sup>[3]</sup>

In Figure 3, DC-DC converters are shown, one charging a 12V battery and another a 48V battery from the main traction DC rail at around 400V. The 12V rail feeds a selection of ancillary equipment including accessible sockets in the cabin for USB chargers for example, so the converter must feature galvanic isolation. Additionally, the 12V lead acid battery is another source of energy so the DC-DC converter is typically bi-directional so that the battery can contribute to traction requirements under emergency conditions. A typical architecture is shown in **Figure 7** with a bridge arrangement of MOSFETs, each side of a transformer, that can be configured as power switches or rectifiers by appropriate PWM drive. The power level is up to around 2kW and the design requires similar filter components to the traction inverter in the form of capacitors, inductors and multiple winding inductor modules and transformers from the suppliers mentioned. Fusing, circuit breakers and fault detection circuitry are also required.

Figure7: Typical EV ancillary DC-DC converter architecture – source TI

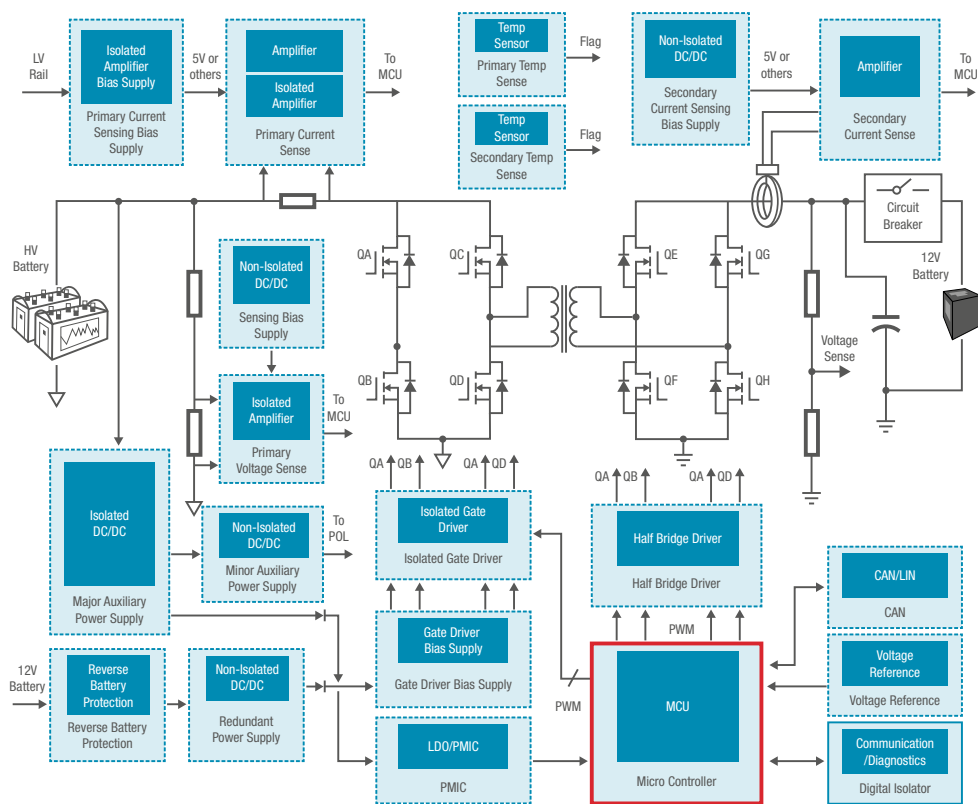

## Summary

The modern electric vehicle in all its forms incorporates all technologies from wireless communications through computing to advanced sensing and power conversion. The operating environment is about as uncontrolled and harsh as it can get, with owners expecting total safety and reliability. Although there have been many approaches to the power conversion architectures in cars, there are robust standards established for performance levels of modules and components with major suppliers responding with ranges of qualified products to choose from. Suppliers can be expected to hold the automotive quality accreditation IATF/TS16949<sup>[4]</sup>, with their products and manufacturing processes meeting the appropriate AEC-Q specification<sup>[5]</sup>. Representation of these suppliers through distributors such as TTI, Inc.<sup>[6]</sup> allows designers quick access to stock for prototyping and approval.

<sup>1</sup> European Automobile Manufacturers Association. <https://www.acea.be/>

<sup>2</sup> Alternative Fuels Observatory. <https://www.afo.eu/>

<sup>3</sup> Monzer Al Sakka, Joeri Van Meerlo and Hamid Gualous (2011). DC/DC Converters for Electric Vehicles, Electric Vehicles - Modelling and Simulations, Dr. Serref Soylu (Ed.), 1 ISBN: 978-953-307-477-1, InTech, Available from: <http://www.intechopen.com/books/electric-vehicles-modelling-and-simulations/dc-dc-converters-for-electric-vehicles>

<sup>4</sup> International Automotive task Force. <https://www.bsigroup.com/en-GB/iatf-16949-automotive/>

<sup>5</sup> Automotive Electronics Council. <http://www.aecouncil.com>

<sup>6</sup> TTI, Inc. <https://www.tti.com>



## About TTI

TTI, Inc. is the world's leading authorized distributor specialist offering passive, connector, electromechanical, discrete, power supplies and sensor components. TTI's extensive product line and supply chain solutions have made the company the distributor of choice for industrial, defense, aerospace and consumer electronic manufacturers worldwide.

TTI's extensive product line includes: resistors, capacitors, connectors, discretes, potentiometers, trimmers, magnetic and circuit protection components, wire and cable, wire management, identification products, application tools, power supplies, sensors and electromechanical devices. These products are distributed from a broad line of leading manufacturers. TTI strives to be the industry's preferred information source by offering the latest IP&E technology and market information through the online MarketEye Research Center. MarketEye includes articles, technical seminars, RoHS, seminars, industry research reports and much more.

TTI's products, personalized service and custom supply chain solutions have earned us the most preferred passives distributor title by CMP Publications. TTI employs more than 5,600 people at more than 100 locations throughout North America, Europe and Asia.

### European Headquarters:

TTI, Inc.  
Ganghoferstr. 34  
82216 Maisach-Gernlinden  
Germany  
Tel.: +49 (0)8142 6680 – 0  
Fax: +49 (0)8142 6680 – 490  
Email: [sales@de.ttiinc.com](mailto:sales@de.ttiinc.com)  
[www.ttieurope.com](http://www.ttieurope.com)

Copyright © TTI, Inc. All Rights Reserved.